

# Products

## Pinch Valve 500

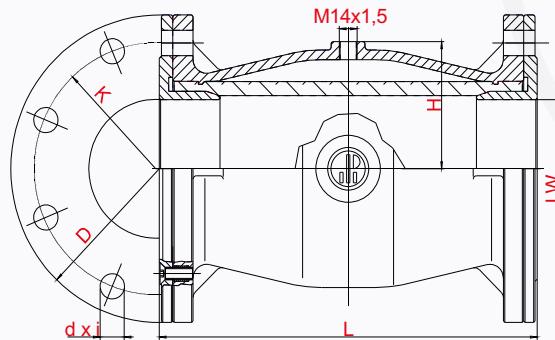

PROVEN & RELIABLE  
FOR USE IN:

INDUSTRIAL

FUEL HANDLING

BULK HANDLING

TANK TRUCK CONSTR.

SILO TRUCK CONSTR.

### PROKOSCH Pinch Valve No. 500

Dual-sided flange per DIN 2501.

The pneumatically activated PROKOSCH 500-series pinch valves were designed specifically for use in silo trucks. They are known for their strength, fewer individual parts and space-saving elements as well as their maintenance-free design. The free cylindrical pass reduces flow resistance to a minimum.

- ▶ Body made of a light alloy with generously dimensioned wall thickness. Flanges made of standard gray cast iron material. Each body is subjected to a burst test at 24 bar at the plant.
- ▶ Long service life due to highly abrasion-resistant sleeve made of NBR/SBR, fabric-reinforced and free cylindrical pass.
- ▶ Sleeve can also be provided in white food-substance quality and stainless steel flanges.
- ▶ Can be dismantled without special tools.
- ▶ Special designs regarding material and design are available upon request.

Nom. width DN	LW	Dimensions					Air pressure	Air volume valve closed (l)	Weight (kg)
		L	D	K	dxi	H			
50	47	205	165	125	18x4	64	5 - 6 bar	1,1	3,3
65	62	205	185	145	18x4	74	5 - 6 bar	1,6	4,7
80	78	225	200	160	18x8	81	5 - 6 bar	2,1	6,1
100	97	280	220	180	18x8	91	5 - 6 bar	3,0	7,9